



## Continuous inkjet 9750 E Series: The advanced printers for extrusion



### The innovation you need. The experience you trust.

We're committed to your industry. Our previous extrusion-specific models provided you with long-lasting, fast-drying, and nonmigrating codes on all materials – even PE. Our proven reliability and full suite of colors – including two of the market's first, reliable MEK-free inks – already enable you to code many materials effectively, sustainably and in the most demanding environments.

The 9750 E series printers take this performance to the next level with:

- Market's **first** ever hybrid ink circuit which can print either standard or premium, contrasted codes, vastly increasing flexibility while cutting spare parts for those needing both options
- Market's **most** environmentally-friendly coding solution, which cuts VOCs\* – even for MEK inks, reduces landfill waste and improves operator safety
- Market's **only** customizable 24-pin interface, so you can integrate the coder to best suit your needs
- One of industry's **highest** uptime due to synchronized parts replacement schedule and up to 18,000 hours between services
- An even larger, 10-inch, smartphone style, user interface to improve operator data entry – specially designed for extrusion applications
- Additional ink options for electronics coding

## Key benefits

### Innovation

Advanced R&D backed by proven industrial processes and methods

- **Market's first hybrid printer** takes dye or pigmented inks so companies can just use one continuous inkjet coder, regardless of ink or packaging
- **Intelli'Inks®** system ensures optimal performance and flexibility when coding different materials—in all colors, with all inks.
- **Intelli'Swap®** technology streamlines mechanicals down to swappable modules.

### Sustainability

More sustainable solutions =  
Long-term value and lower TCO\*

- **Intelli'Design®** process and MEK-free inks help cut consumable consumption and VOC\* emissions by up to 40-60% depending on mode used. Up to -35% even for MEK inks when using CSM\*.
- **IntelliSwap®** means you synchronize parts replacement and swap only individual items, not the entire block.
- **Market-leading service intervals** of up to 18,000 hours.

### Digitalization

Market's most easily customizable  
integration

- Currently market's only provider of 24-pin interface customizable to accept any of the 70+ signals available to run lines.
- M12 input/output connector and compatible with various industrial protocols, enabling easier and more seamless integration.
- MiVista™ connected printer services powered by a secure IoT\* platform\*\*, allow for predictive analysis and to help maximize uptime AND achieve OEE\* objectives.

# 9750 E Series continuous inkjet specifications

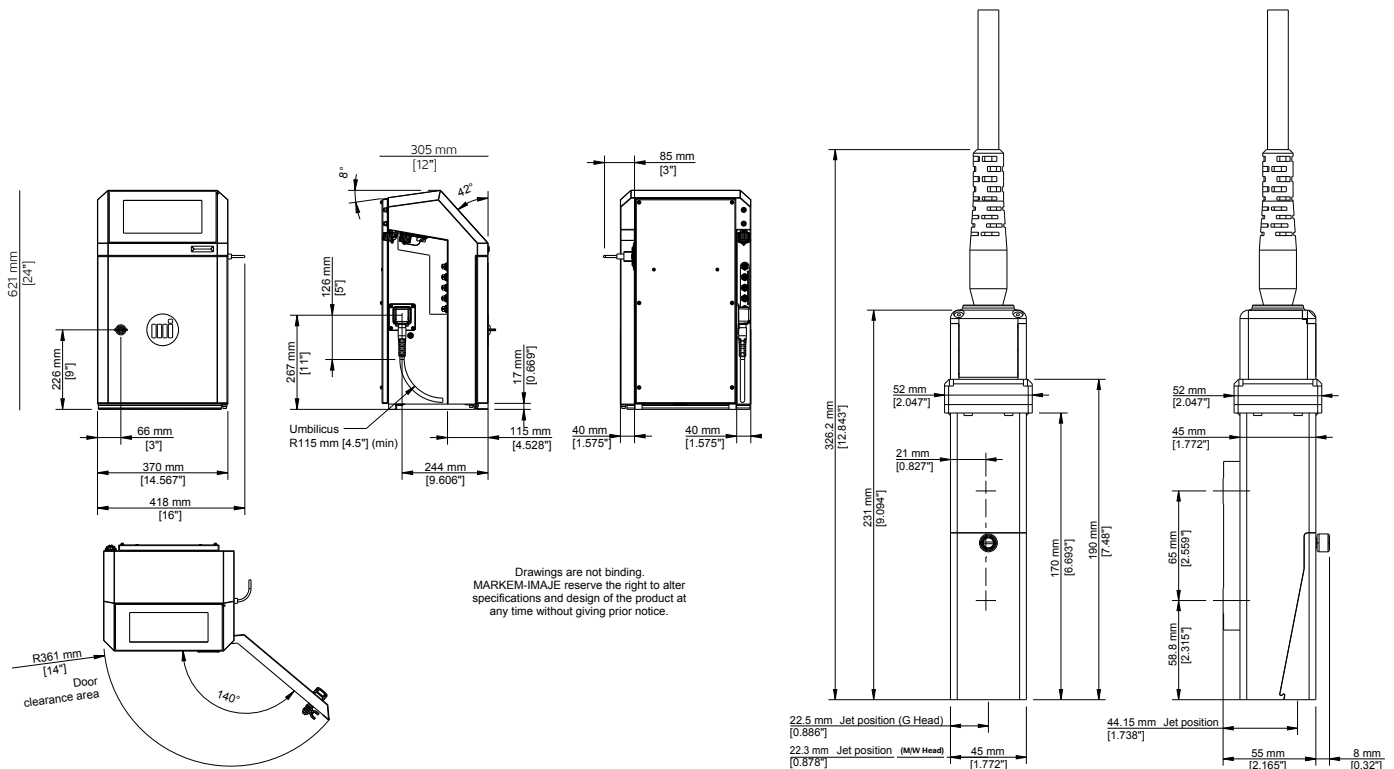

## Print features

Mono-jet printhead  
G head (printing resolution: 71 dpi)  
M head (printing resolution: 115 dpi)  
W head (printing resolution: 71 dpi)  
Up to 5 lines of print

Print speed: up to 1,000 m/min  
Font height from 5 to 32 dots  
Character height: from 1.2 to 11.2 mm

Wide choice of 1D and 2D barcodes: EAN8/ EAN13/ GS1-128/UPCA/UPCE barcodes, code 39, code 128, interleaved 2 of 5, Datamatrix, QR code

Wide choice of characters: Latin, Arabic, Cyrillic, Hebrew, Japanese, Chinese, Korean, etc.

## Other characteristics

Weight: 25 kg  
Table-top or vertical mounting  
Ultra-flexible 3-meter umbilical cable  
Stainless steel cabinet and printhead case  
Dust/water ingress protection rating: IP56 requiring no plant air  
Operating temperature range: 32 °F to 122 °F (0 °C to 50 °C) depending on ink used  
Humidity: 10 to 90% non-condensing  
Electrical power supply: 100-240 V; 1.6 A; frequency 50-60 Hz; 30 W

## Operations

WYSIWYG 10-inch capacitive color touchscreen: real-time display of remaining print capacity expressed in hours and number of messages; integrated assistance and alert system; simplified message printing and management; creation of user profiles; tracking of consumption and printer availability  
Message library (up to 1,000 messages)  
Additional functionalities: metering, interleaving of

2 messages, on-the-fly production changes, quick access to counter setting, optimization of tolerance control, chimney characters, DIN mode

Automatic selection of fonts, depending on print speed and printhead/object distance  
Specific date management (rounding date function)  
Parent/child connectivity

Jet Speed Control to guarantee marking quality  
Printhead with embedded intelligence for high marking quality and reduced maintenance

Broad range of dye and pigment inks: multi-use, high performance; alcohol based, ketone-free and MEK-free inks

Sealed 0.6 and 0.8-liter consumable cartridges with foolproof system

Compact and modular ink circuit for better thermal management and controlled additive consumption

Up to 18,000 hours between major services for dye prints and up to 9,000 hours for pigmented codes  
100% front access modular ink circuit for click-in, click-out maintenance or repair

Remote services including Miva™, intelligent self-support solution for 24/7 self-troubleshooting and "how to" videos

Quick connect/disconnect of accessories (photocell, alarm and encoder)

Enhanced native connectivity including USB, Ethernet, serial and a configurable M12 connector for I/O

## Remote services

Miva™, intelligent self-support solution: 24/7 selftroubleshooting and "how to" videos. Live helpdesk support with remote video capabilities

MiVista™ connected printer services powered by a secure IoT platform\*\*

## Options

Ultra-flexible 6-meter umbilical cable

IP66 protection (plant air required)

Consumable-saving mode (CSM) for up to -60% additive consumption and VOC emission reduction for MEK-free inks, or up to -35% for MEK-based inks. Less than 2 cc/h for MEK-free ink and less than 3.5 cc/h for MEK inks at 20 °C

Printhead pressurization kit; air blade kit

Many I/O possibilities including a configurable single point connector (24 pins) capable of accepting 70+ signals

## Accessories

Wide range of accessories

Printer supports: stands (stainless steel or aluminum), table or wall mounting brackets

Printhead supports: stand (stainless steel) and choice of brackets

Photocells

Pigment ink shaker

Encoders

Alarm beacons (24 V)

Set of pre-cabled connectors M12, Ethernet IP66

## Software

Fully compatible with CoLOS® Version 6.4 Service Pack onwards

Logo creation with CoLOS® Graphics software

\*TCO: Total cost of ownership. VOC: Volatile organic compounds. CSM: Consumable saving mode. IoT: Internet of things. OEE: Overall equipment effectiveness. \*\*Please check availability in your country



a DOVER company

9, rue Gaspard Monge - B.P. 110  
26501 Bourg-lés-Valence Cedex France  
+33 (0) 4 75 75 55 00  
[markem-imaje.com](http://markem-imaje.com)